

CAT. No.

57730

IEC 60320 (320) C-20 INLET WITH INTEGRAL DOUBLE POLE (DPST) ON/OFF ROCKER SWITCH. SCREW MOUNT FROM FRONT OR BACK. 6.3 x 0.8 mm QUICK CONNECT TERMINALS. BLACK. UL 94V-O. RATED 20 AMPERE 125-250 VOLT AC (UL/CSA), 16 AMPERE 250 VOLT AC (VDE)

APPROVALS / CERT'S.

CSA

UL

VDE

ALL DIMENSIONS ARE IN MILLIMETERS

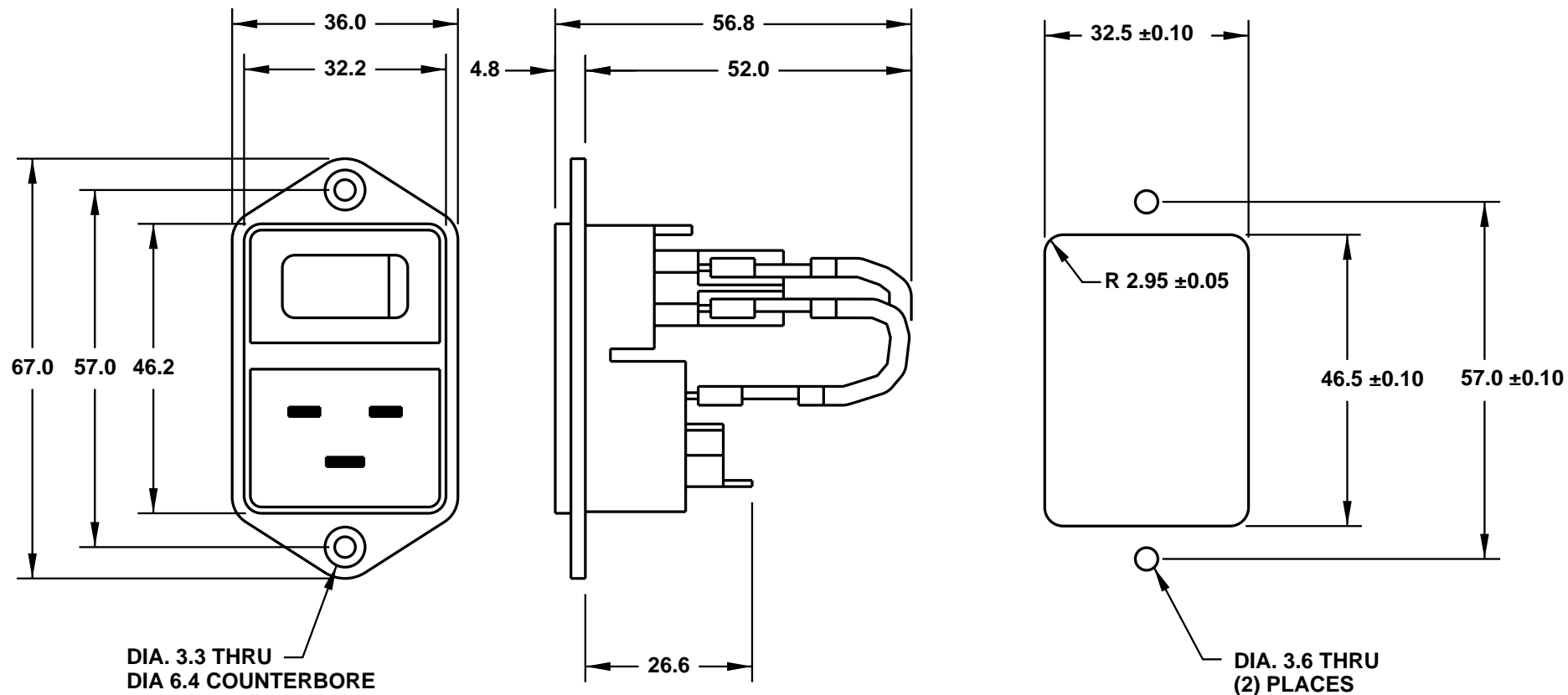

PANEL CUTOUT