

CAT. No.
70124

EUROPEAN "SCHUKO" OUTLET (APPROVED IN SWEDEN), WEATHERPROOF IP 44 RATED, SCREW MOUNT,
GREY, 2 POLE 3 WIRE, 16 AMPERE 250 VOLT, (EU1-16R)
STANDARD: CEE 7 - 7

APPROVALS / CERT'S. OVE SEMKO VDE

ALL DIMENSIONS ARE IN MILLIMETERS

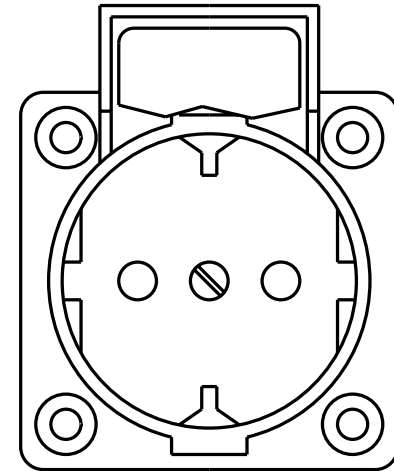

NOTE: FOR CLARITY THIS VIEW IS SHOWN WITH LIFT LID REMOVED

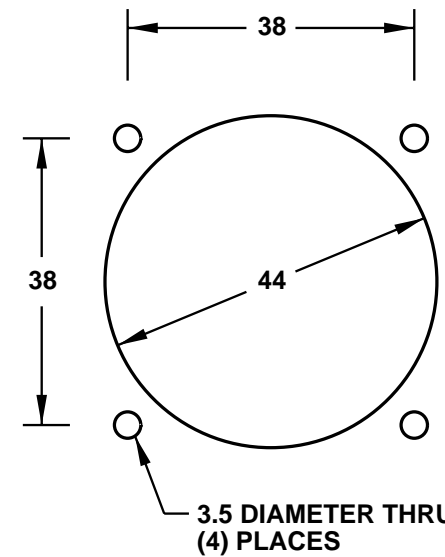
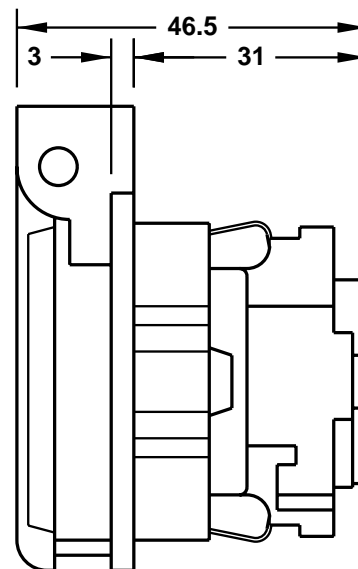
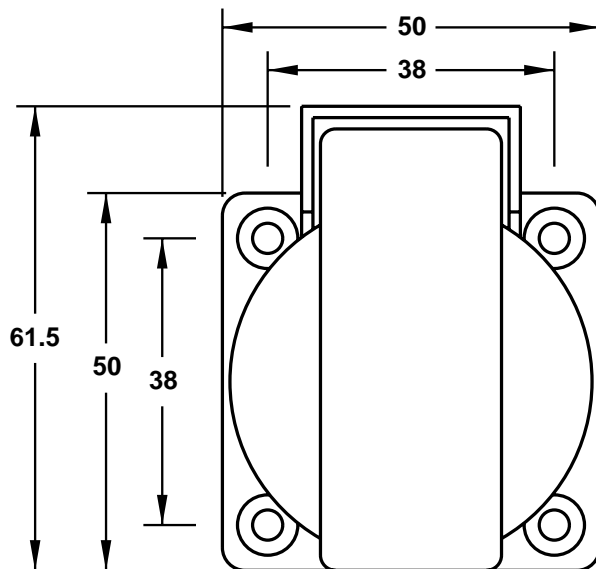

PANEL CUTOUT