

CAT. No.
70180

EUROPEAN "SCHUKO" WEATHERPROOF INLET, BLACK, WITH SWITCH, 2 POLE 3 WIRE, 16 AMPERE 250 VOLT,
(EU1-16P)
STANDARD: CEE-7

APPROVALS / CERT'S.

VDE

ALL DIMENSIONS ARE IN MILLIMETERS

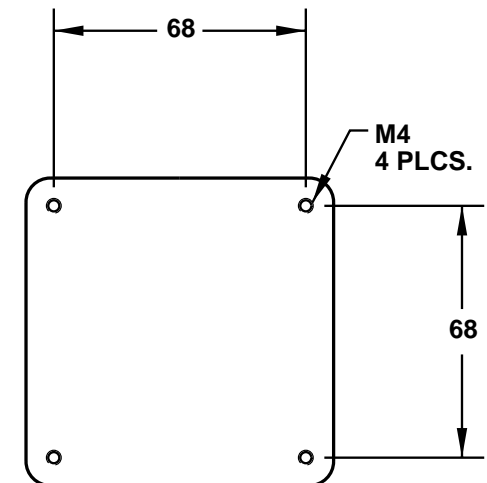
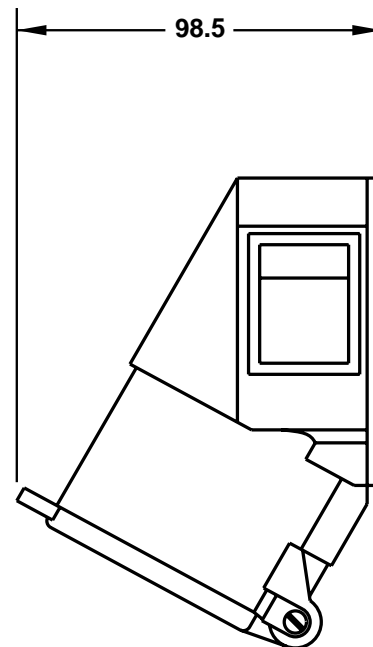
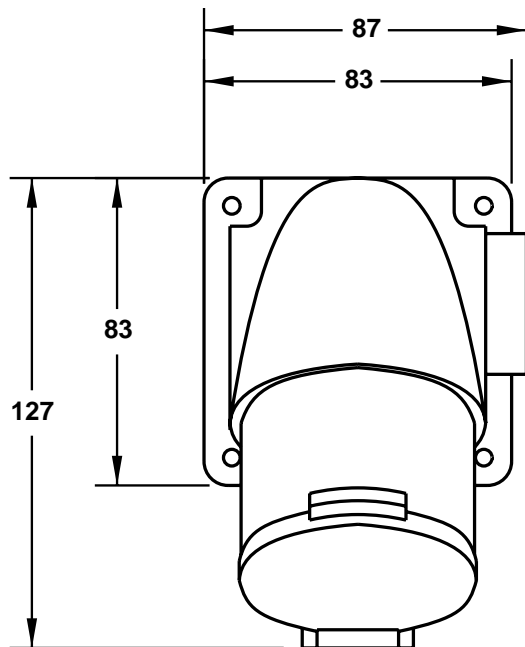

MOUNTING ARRANGEMENT