

CAT. No.  
**70190**

EUROPEAN "SCHUKO" WEATHERPROOF INLET, BLACK, 2 POLE 3 WIRE, 16 AMPERE 250 VOLT, (EU1-16P)  
STANDARD: CEE-7

APPROVALS / CERT'S.

VDE

ALL DIMENSIONS ARE IN MILLIMETERS

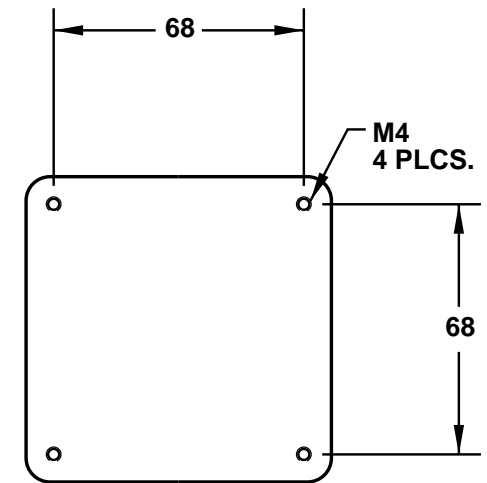
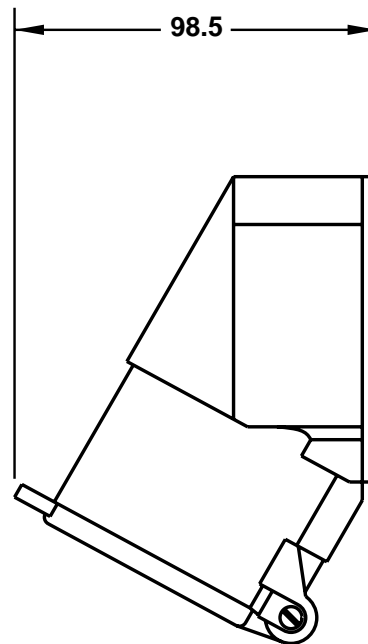
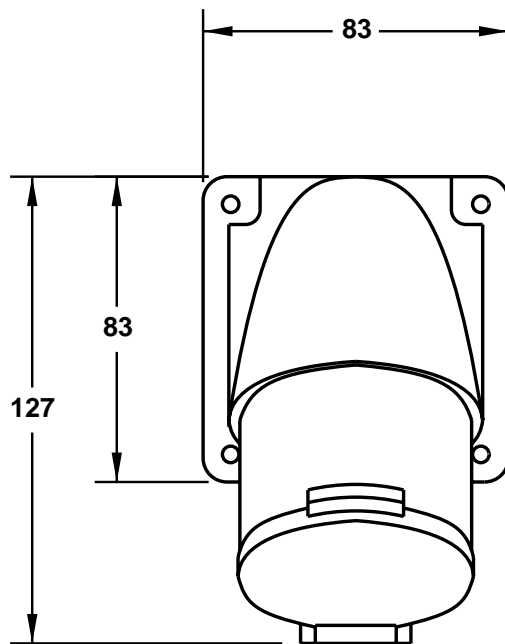

**MOUNTING ARRANGEMENT**