

CAT. No.

888-611316

IEC 60309 SPLASHPROOF (IP44) ANGLE INLET, PANEL MOUNT, 4H, YELLOW COLOR, 20 AMPERE-125 VOLT (UL/CSA), 2P+E.

APPROVALS

CSA UL

CERTIFICATIONS

CE ROHS

STANDARDS

IEC 60309

ALL DIMENSIONS ARE IN MILLIMETERS

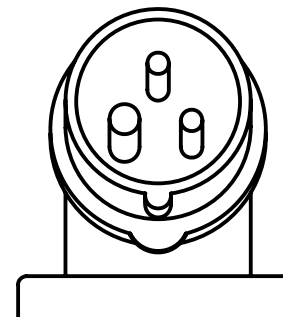
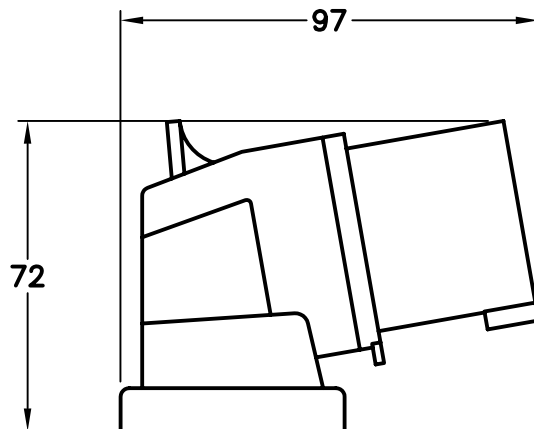
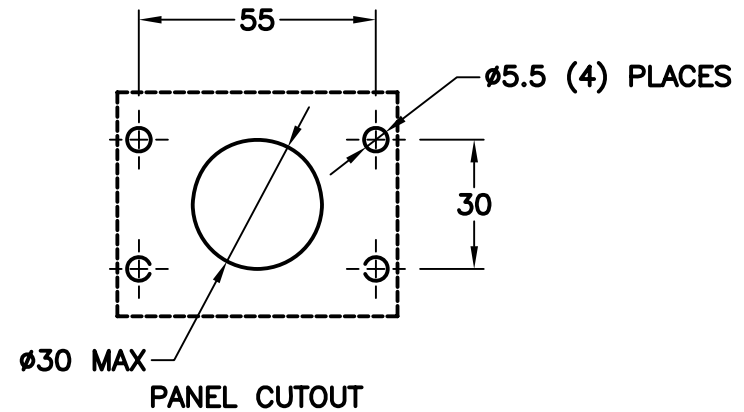
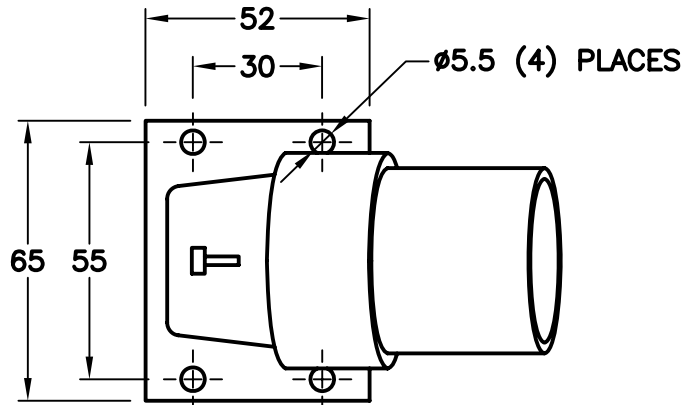

IEC 60309, 4H