

CAT. No.
888-6136

IEC 309 CEE 17 INLET, STRAIGHT PANEL MOUNT, BLUE, 20 AMPERE 250 VOLT (UL / CSA),
16 AMPERE 220 / 240 VOLT (EUROPEAN), 50 / 60 HZ , 2 POLE + EARTH
STANDARDS: IEC 309-1, IEC 304-2, BS 4343, DIN 49462/63, VDE 0623, CEE 17, EN 60309

APPROVALS / CERT'S.

CSA

SEMKO

UL

ALL DIMENSIONS ARE IN MILLIMETERS

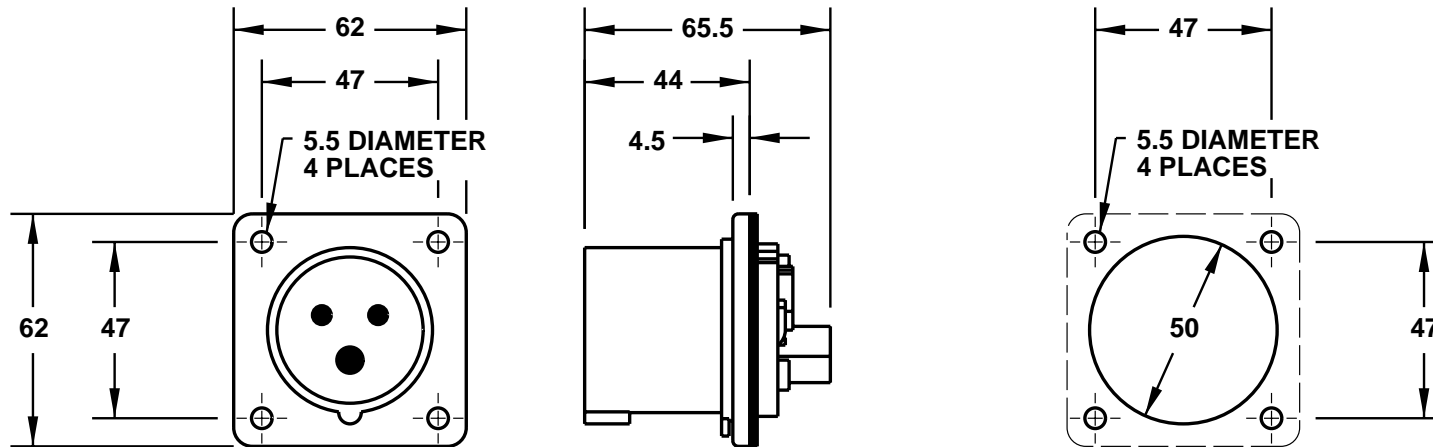

PANEL CUTOUT

www.InternationalConfig.com
sales@internationalconfig.com